

CATALOGUE

Bulk Handling / Industrial Rollers



BULK HANDLING ROLLERS
IR5500 Series | Page



WING SIDE BULK HANDLING ROLLERS
IR550 Wing Series | Page



IMPACT & DISC RETURN ROLLERS
IR550-IM Series | Page

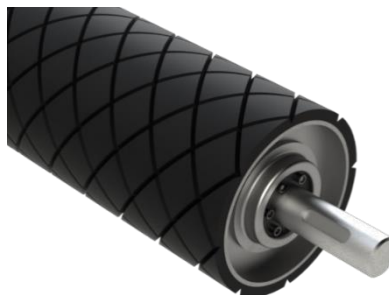

DRUM ROLLERS
Page

IR5500 SERIES

Bulk Handling Conveyor Rollers

IR 5500 SERIES of industrial rollers - perfect solution for heavy-duty industrial applications. Made exclusively from high-quality mild steel, these rollers are designed to provide superior performance and longevity in a variety of industries.

The IR 5500 series is ideal for use in industries such as Bulk Handling mining, manufacturing, construction, and many others. They are engineered to withstand heavy loads, harsh environments, and extreme temperatures, making them suitable for even the most challenging applications.

At our company, we understand that every application is unique, and that's why we offer made-to-measure IR 5500 rollers to suit your specific needs.

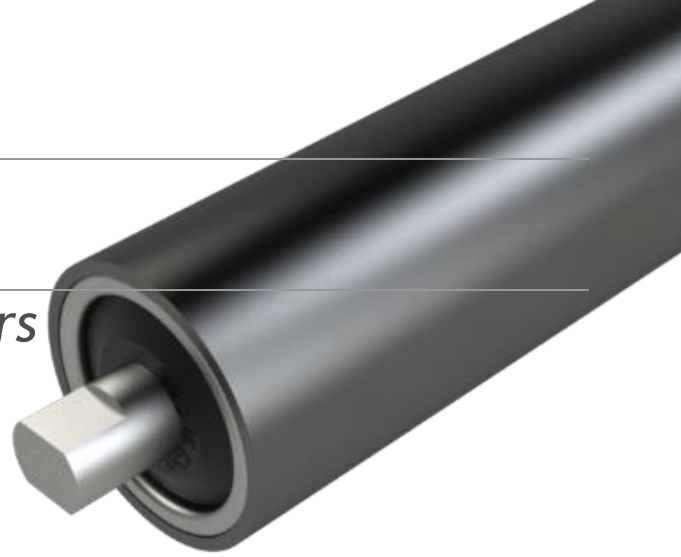

-20<80°C



APPLICATIONS

Recycling Plants Offshore / Ships

Airports Quarries

Extra Heavy Duty Steel Construction Conveyors

Roller Type	Tube Dia (mm) & thickness	Axle Options (mm)	Tube Finish Options.
		●	Default self-colour. BZP & painted are optional extra
IR51	50.8 x3.0	20 25	Self Colour BZP
IR60	60 x3	20	Self Colour BZP Spray Black
IR63	63.5 x3.0	20 25	Self Colour BZP Spray Black
IR70	70 x3.0	20	Self Colour BZP Spray Black
IR76	76 x3.0	20 25	Self Colour BZP Spray Black
IR89	89 x3.0	20 25	Self Colour BZP Spray Black
IR4	101.6 x3.0	20 25	Self Colour BZP Spray Black
IR108	108 x3.0	20 25 30	Self Colour BZP Spray Black
IR127	127 x3.6	25 30	Self Colour BZP Spray Black
IR133	133 x3.6	25 30	Self Colour Spray Black
IR6HD9	140 x9.0	25 30	Self Colour Spray Black
IR159	159 x4.5	30 35 40	Self Colour Spray Black
IR168	168 x6.0	35	Self Colour Spray Black

Most Popular Axle Finish Options
ask a member of the AED team for more options

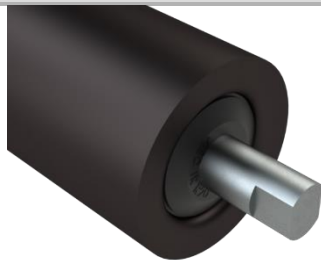

Flatted



Male Thread



Female Thread

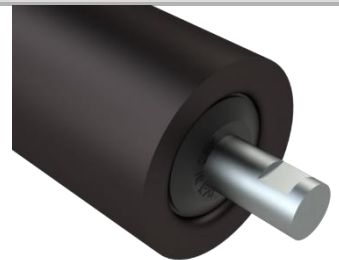

U Bolt

BEST SELLER: IR89-20-AX2 (FLATTED)

Not what you're looking for? Try our "IR Wing Series"

IR5500 WING SERIES

Wing/Side Bulk Handling Rollers

Popular within recycling plants & quarries, our **IR WING SERIES** is a robust steel roller with axle protruding 1 side only. Mainly used in bulk handling but also can be positioned vertically to act as product guide rollers.

These rollers consist of a mild steel tube (supplied self-colour as standard, or upgrade to painted black or BZP finish for extra protection from the elements), all steel endcaps & a sealing system to protect the bearings for longest life.

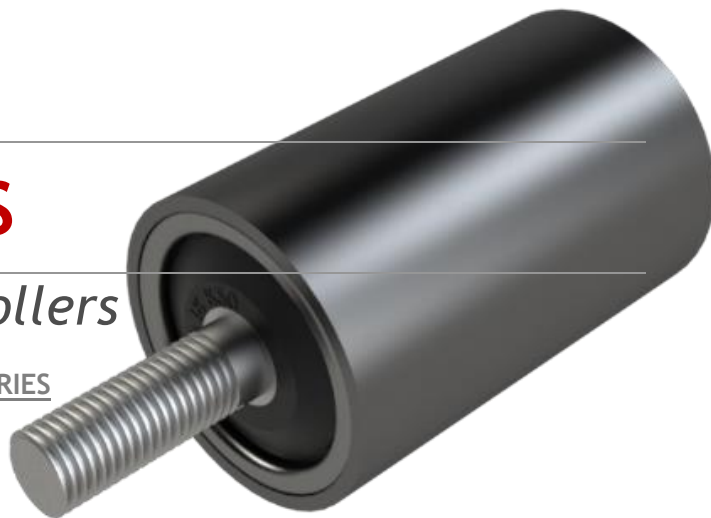

-20<80 °C



APPLICATIONS

Recycling Plants Offshore / Ships
Mining & Quarries

Roller Type	Tube Dia (mm) & thickness	Axle Options (mm)	Tube Finish Options.
		●	Default is self-colour unless otherwise stated
IR51	50.8 x3.0	20 25	Self Colour BZP
IR60	60 x3	20	Self Colour BZP Spray Black
IR63	63.5 x3.0	20 25	Self Colour BZP Spray Black
IR70	70 x3.0	20	Self Colour BZP Spray Black
IR76	76 x3.0	20 25	Self Colour BZP Spray Black
IR89	89 x3.0	20 25	Self Colour BZP Spray Black
IR4	101.6 x3.0	20 25	Self Colour BZP Spray Black
IR108	108 x3.0	20 25	Self Colour BZP Spray Black
IR127	127 x3.6	25	Self Colour BZP Spray Black
IR133	133 x3.6	25	Self Colour Spray Black

Most Popular Axle Finish Options ask a member of the AED team for more options

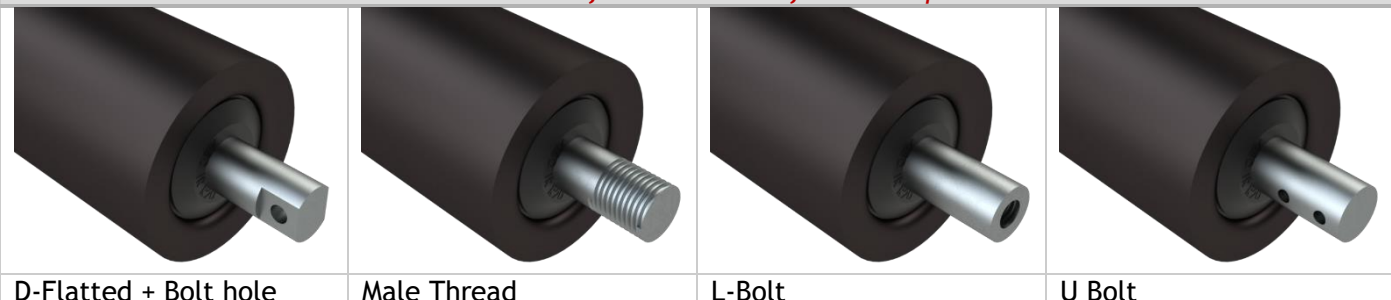

BEST SELLER: IR4-20-WING-AX6 MALE THREAD

Not what you're looking for? Try our "IM Series"

IR5500-IM SERIES

Impact & Disc Return Rollers

Popular within recycling plants & quarries, our IR-IM SERIES are for bulk handling:

Impact Rollers & Disc Return Rollers can withstand abrasive environments & heavy aggregate with 3 common ring configurations

These rollers consist of a mild steel tube (supplied self colour or painted), Durable rubber impact rings, all steel endcaps & a sealing system to protect the bearings for longest life.

Ring collars can also be added either side of the rubber rings to prevent movement while under load.

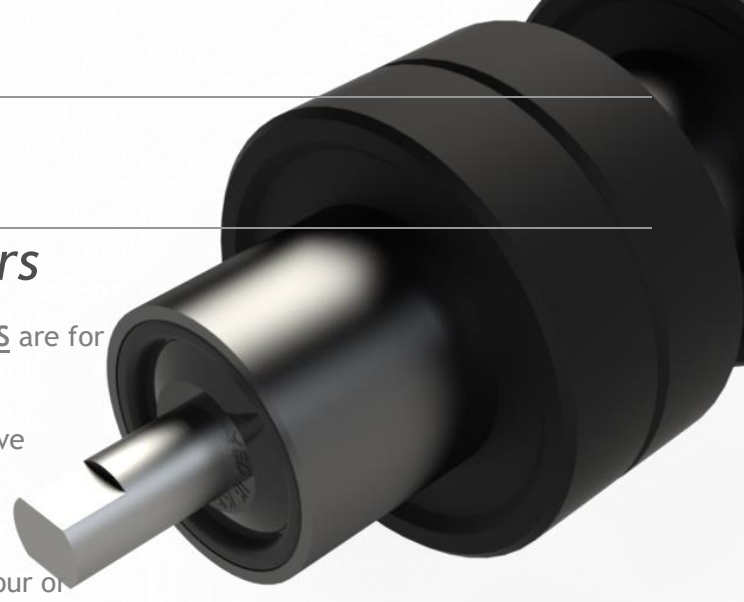

-20<80 °C



APPLICATIONS

Recycling Plants Quarries

Roller Type	Tube Dia (mm) & thickness	Impact Ring Sizes (FOD x Width mm)		Axle Options (mm)	Tube Finish *Optional extra Painted available
				●	
IR63IM108B	63.5x3.0	108x40 RING TYPE B		20 25	Self Colour
IR63IM108C	63.5x3.0	108x30 RING TYPE C		20 25	Self Colour
IR63M133C	63.5x3.0	133x30 RING TYPE C		20 25	Self Colour
IR63IM150C	63.5x3.0	150x30 RING TYPE C		20 25	Self Colour
IR89IM133B	89 x3.0	133x40 RING TYPE B		20 25 30	Self Colour
IR89IM133C	89 x3.0	133x35 RING TYPE C		20 25 30	Self Colour
IR89IM150B	89 x3.0	150x40 RING TYPE B		20 25 30	Self Colour
IR63IM150C	89 x3.0	150x35 RING TYPE C		20 25 30	Self Colour

Ring Configurations

Roller build option as per Page 1. Ask a member of the AED team for more options

Ring quantity Required			
	Config A	Config B	Config c

BEST SELLER: CONFIG A, IR89M150C-25-AX2 (FLATTED)

Not what you're looking for? Try our "Drum Rollers"

DRUM (PULLEY) SERIES

Conveyor Drum Rollers

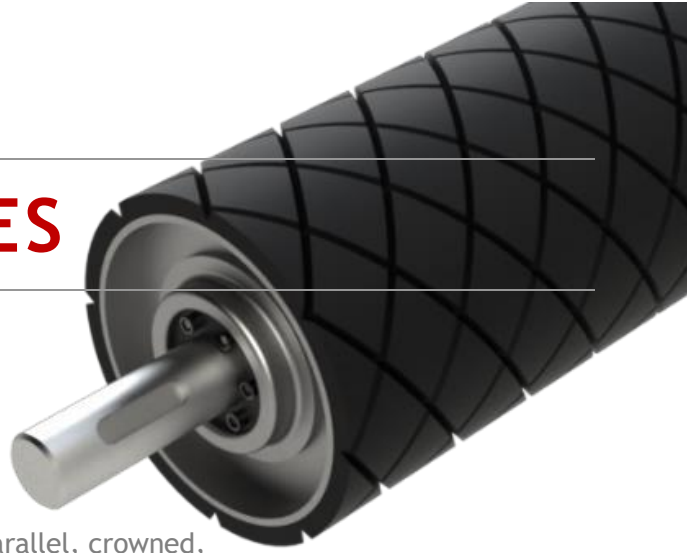

Our heaviest range yet! We make our CONVEYOR DRUM SERIES in house, custom to your requirements.

The cylindrical mild steel shell is completed with a choice of parallel, crowned, tracking groove or rubber lagged finish. Maximum possible diameter offered is 254mm. AED machine bespoke endcaps to suit your choice of drum dia and chosen axle size.

Different to other brands, AED have incorporated keyless RCK clamps, allowing the axle to be removed for replacement when life remains in the body of the drum. An innovative, economical choice for your conveyor whilst smart financially.

-20<80°C





APPLICATIONS

Machine Turned Under Belt Drive

Tube Dia Suggestions (mm)				Axle Dia Suggestions (mm)	Tube Finish Options	Max Length
60	114	152	219	20 25 30 35 40 50 <i>mild steel / stainless steel axle only</i>	Parallel Crowned Tracking Groove Rubber Lagged Polyurethane Covered	2400mm (2.4m)
76	121	159	229			
89	127	168	244			
95	133	178	254			
102	139	194	267			
108	146	203				

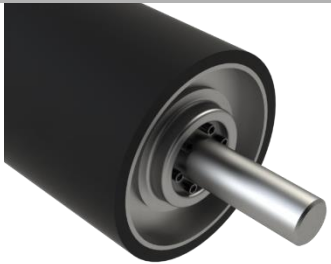
Most Popular Axle Finish Options *ask a member of the AED team for more options*

			
Plain	Plain + Rubber Covered	Keyway	Keyway+Diamond Lagged

BEST SELLER:

Not what you're looking for? Try our "IR Series"

Roller Order Form

DATE:		QTY:		IMPACT RINGS	108	EXTRA DETAIL:	
					133		
					150		
Roller Dimensions		Axle Type					
A							
B		E					
C		F					
D		G					
TYPE 2				TYPE 7			
TYPE 3				TYPE 8			
TYPE 4				TYPE 10			
TYPE 5				TYPE 14			